



By appointment to The Royal Danish Court

morsø

since 1853



MORSØ FORNO GAS GRANDE

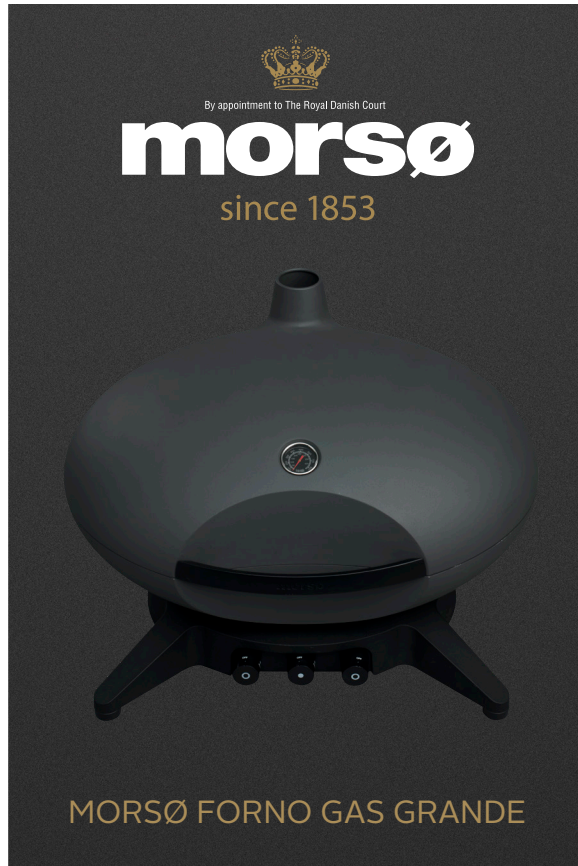

MORSØ FORNO GAS GRANDE

TECHNICAL DATA

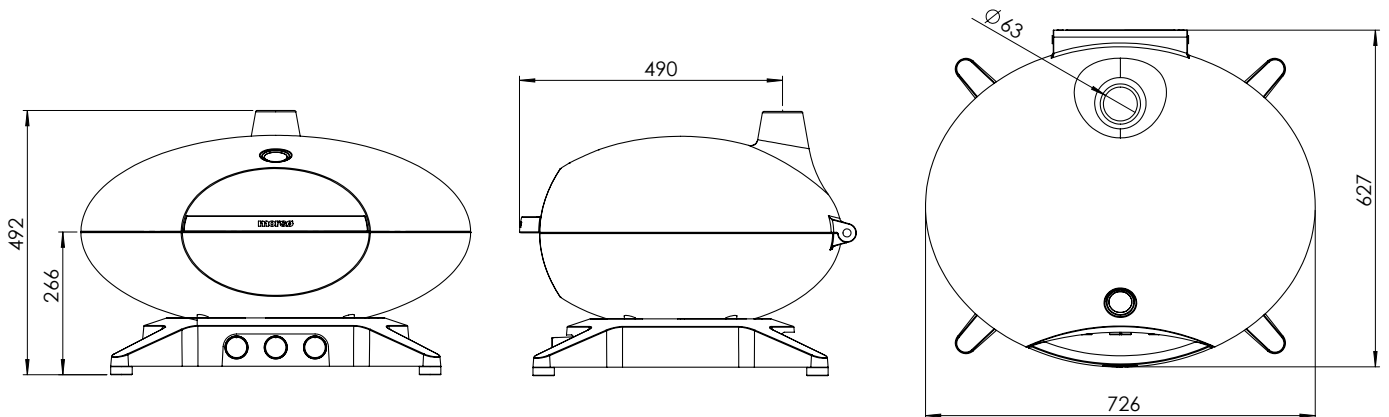

FORNO GAS GRANDE

The lid and pan of the gas BBQ are in precision-cast aluminium, whereas the cooking grate is made of sturdy enamel-coated cast iron. The materials have been carefully selected in order to provide you with good cooking experiences with your new BBQ, which, at the same time, also needs to be easy to clean.



Height	492 mm
Width	726 mm
Depth	627 mm
NW (kg)	26,1 kg
GW (kg)	35 kg
Colour	Anthracite grey
Material	Aluminium
Cooking grate surface/cast iron grate	D580 x W705 mm
Designer	Klaus Rath

Gas system:
 Nominal heat output: 7,4 kw
 Mass flow rates: G30:538g/h;G31:529g/h
 Gas type: Liquid gas - L.P.G. (propane, butane)
 Gas and supply pressure: G30 butane and G31 propane at 30 mbar

Burner: Main burner x 3
 Nominal heat input: Left: 2,3 kW + Centre: 2,8 kW + right: 2,3 kW
 Size of burner injector: 0,74/0,8/0,74 mm

Items per 40'HC container: 280 items/EU pallet 4 items